

D0801 SERIES

0.80mm pitch wire to board connector

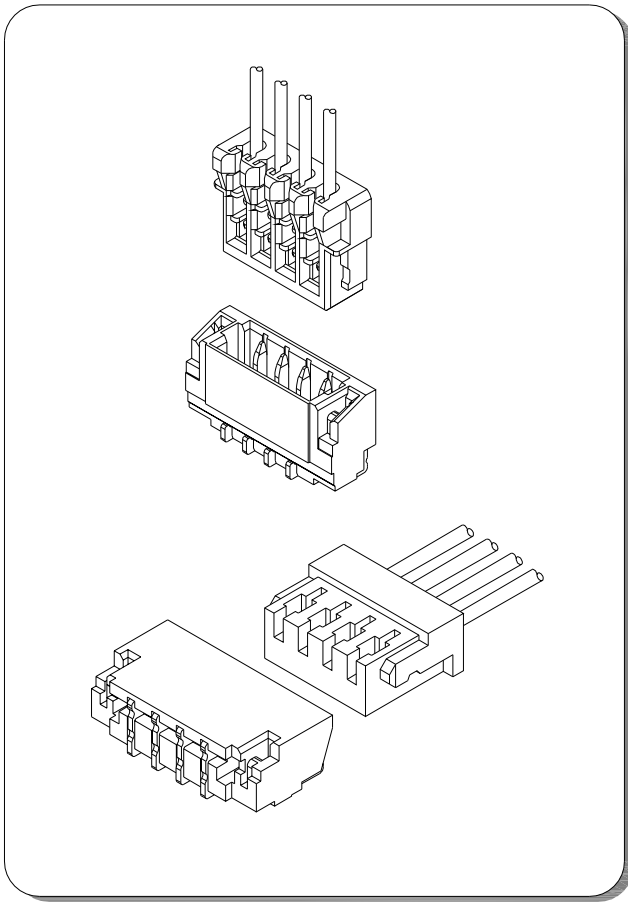

Specifications

- Current rating:0.5A AC,DC
- Voltage rating:30V AC,DC
- Temperature range:-40°C~+105°C
- Contact resistance:20mΩMax.
- Insulation resistance:100MΩMin.
- Withstanding voltage:200V AC/minute
- *Compliant with RoHS and REACH*
- *Meet the HF/Halogen Free,need to customize*
- *Contact for details*

Standards



Assembly layout

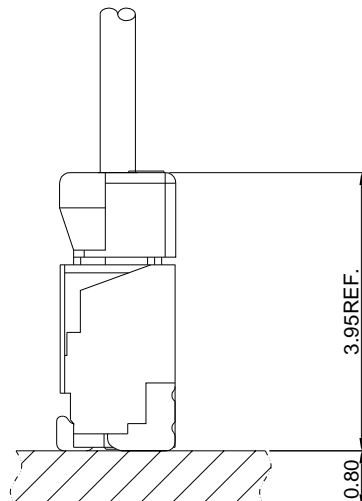
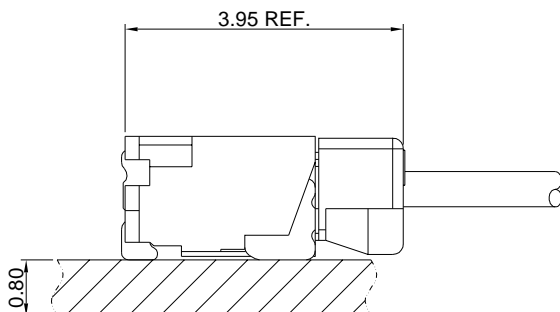

D0801 SERIES

0.80mm pitch wire to board connector

D0801H

0.80mm pitch Insulation Displacement Connector

Reference Informations:

*Material:

Terminal: Phosphor Bronze/Tin over Nickel

Housing: Nylon 46, UL94V-0

*Mates with D0801 series Wafer

*Color: Beige

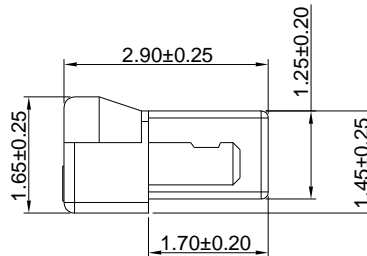
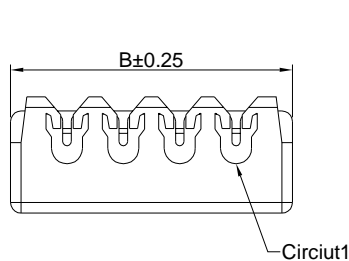
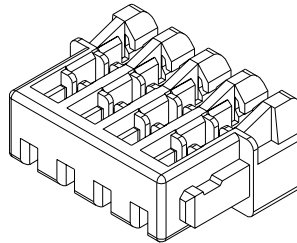
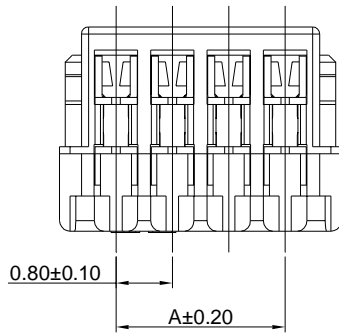

Ordering Information & Dimensions:

PART NO.	Dimensions	
	A	B
D0801H-2P	0.80	2.40
D0801H-3P	1.60	3.20
D0801H-4P	2.40	4.00
D0801H-5P	3.20	4.80
D0801H-6P	4.00	5.60
D0801H-7P	4.80	6.40
D0801H-8P	5.60	7.20
D0801H-9P	6.40	8.00
D0801H-10P	7.20	8.80
D0801H-11P	8.00	9.60
D0801H-12P	8.80	10.40
D0801H-13P	9.60	11.20
D0801H-14P	10.40	12.00
D0801H-15P	11.20	12.80
D0801H-16P	12.00	13.60
D0801H-17P	12.80	14.40
D0801H-18P	13.60	15.20
D0801H-19P	14.40	16.00
D0801H-20P	15.20	16.80
D0801H-21P	16.00	17.60
D0801H-22P	16.80	18.40

Unit: mm

D0801WV-S

0.80mm pitch 180° Wafer -SMT TYPE

Reference Informations:

*Material:

Terminal: Phosphor Bronze/Tin over Nickel

Solder Tabs: Brass/Tin over Nickel

Housing: Nylon 6T, UL94V-0

*Mates with D0801 series Housing

*Color: Beige

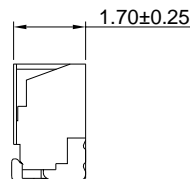
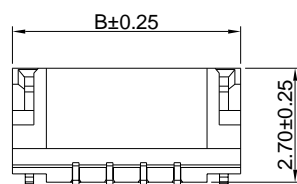
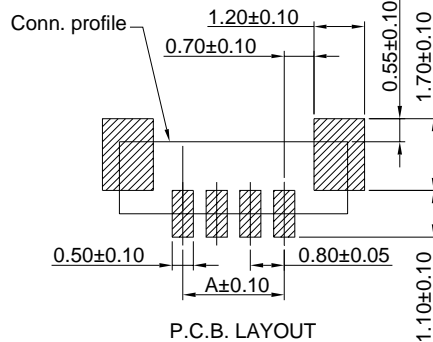
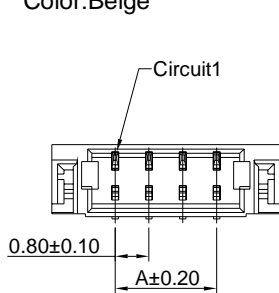
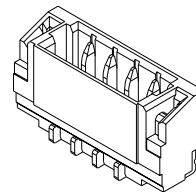

Ordering Information & Dimensions:

PART NO.	Dimensions	
	A	B
D0801WV-S-2P	0.80	3.80
D0801WV-S-3P	1.60	4.60
D0801WV-S-4P	2.40	5.40
D0801WV-S-5P	3.20	6.20
D0801WV-S-6P	4.00	7.00
D0801WV-S-7P	4.80	7.80
D0801WV-S-8P	5.60	8.60
D0801WV-S-9P	6.40	9.40
D0801WV-S-10P	7.20	10.20
D0801WV-S-11P	8.00	11.00
D0801WV-S-12P	8.80	11.80
D0801WV-S-13P	9.60	12.60
D0801WV-S-14P	10.40	13.40
D0801WV-S-15P	11.20	14.20
D0801WV-S-16P	12.00	15.00
D0801WV-S-17P	12.80	15.80
D0801WV-S-18P	13.60	16.60
D0801WV-S-19P	14.40	17.40
D0801WV-S-20P	15.20	18.20
D0801WV-S-21P	16.00	19.00
D0801WV-S-22P	16.80	19.80

D0801 SERIES

0.80mm pitch wire to board connector

D0801WR-S

0.80mm pitch 90° Wafer -SMT TYPE

Reference Informations:

*Material:

Terminal: Phosphor Bronze/Tin over Nickel

Solder Tabs: Brass/Tin over Nickel

Housing: Nylon 6T, UL94V-0

*Mates with D0801 series Housing

*Color: Beige

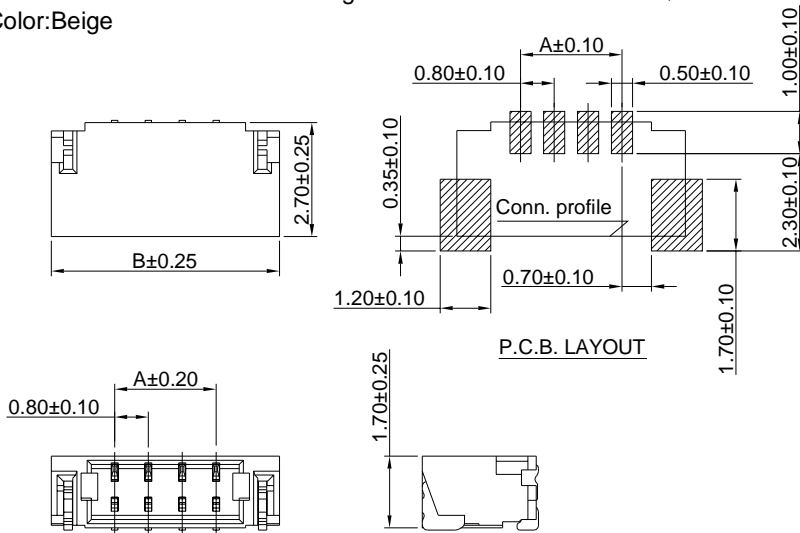
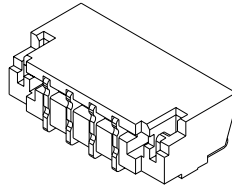

Ordering Information & Dimensions:

PART NO.	Dimensions	
	A	B
D0801WR-S-2P	0.80	3.80
D0801WR-S-3P	1.60	4.60
D0801WR-S-4P	2.40	5.40
D0801WR-S-5P	3.20	6.20
D0801WR-S-6P	4.00	7.00
D0801WR-S-7P	4.80	7.80
D0801WR-S-8P	5.60	8.60
D0801WR-S-9P	6.40	9.40
D0801WR-S-10P	7.20	10.20
D0801WR-S-11P	8.00	11.00
D0801WR-S-12P	8.80	11.80
D0801WR-S-13P	9.60	12.60
D0801WR-S-14P	10.40	13.40
D0801WR-S-15P	11.20	14.20
D0801WR-S-16P	12.00	15.00
D0801WR-S-17P	12.80	15.80
D0801WR-S-18P	13.60	16.60
D0801WR-S-19P	14.40	17.40
D0801WR-S-20P	15.20	18.20
D0801WR-S-21P	16.00	19.00
D0801WR-S-22P	16.80	19.80

Unit: mm