

C2521 SERIES

2.50mm pitch wire to wire connector

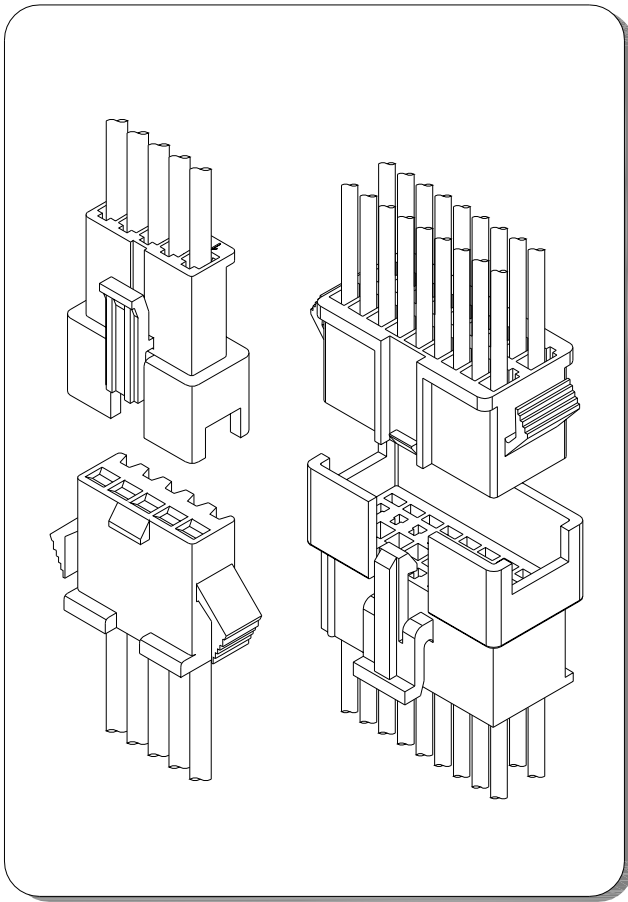

Specifications

- Current rating:3A AC,DC
- Voltage rating:250V AC,DC
- Temperature range:-40°C~+105°C
- Contact resistance:10mΩ Max.
- Insulation resistance:500MΩ Min.
- Withstanding voltage:1500V AC/minute
- *Compliant with RoHS and REACH*
- *Meet the HF/Halogen Free,need to customize*
- *Contact for details*

Standards



Assembly layout

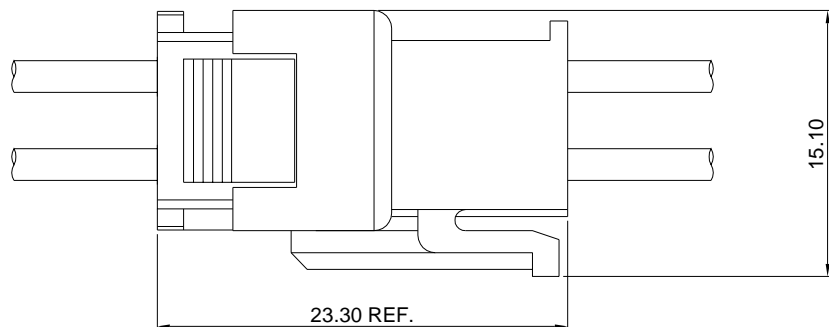
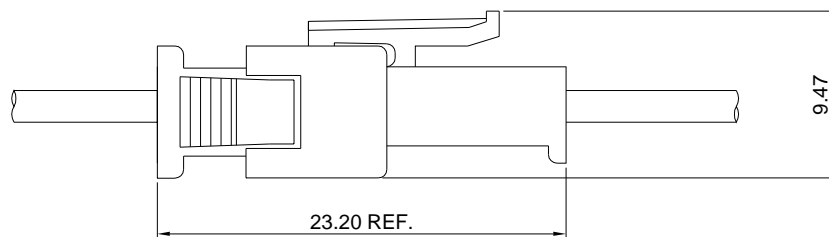

Panel hole layout

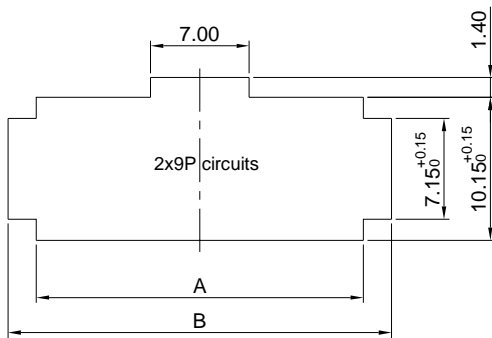
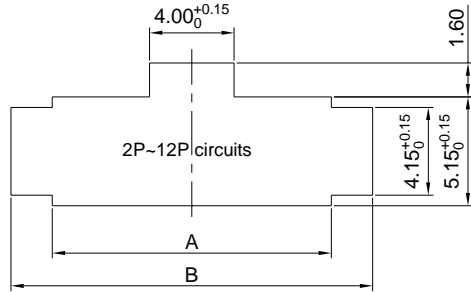

PART NO.	Panel thickness(mm)					
	0.50~0.90		1.00~1.50		1.50~2.00	
	A	B	A	B	A	B
C2521HF-2P	5.70	9.60	5.70	9.80	5.70	10.00
C2521HF-3P	8.20	12.10	8.20	12.30	8.20	12.50
C2521HF-4P	10.70	14.60	10.70	14.80	10.70	15.00
C2521HF-5P	13.20	17.10	13.20	17.30	13.20	17.50
C2521HF-6P	15.70	19.60	15.70	19.80	15.70	20.00
C2521HF-7P	18.20	22.10	18.20	22.30	18.20	22.50
C2521HF-8P	20.70	24.60	20.70	24.80	20.70	24.00
C2521HF-9P	23.20	27.10	23.20	27.30	23.20	27.50
C2521HF-10P	25.70	29.60	25.70	29.80	25.70	30.00
C2521HF-11P	28.20	32.10	28.20	32.30	28.20	32.50
C2521HF-12P	30.70	34.60	30.70	34.80	30.70	35.00
C2521HF-2x9P	23.20	27.20	23.20	27.40	23.20	27.60

Unit:mm

C2521 SERIES

2.50mm pitch wire to wire connector

C2521F-T

2.50mm pitch Crimp Terminal

Reference Informations:

*Used in C2521HF series Housing

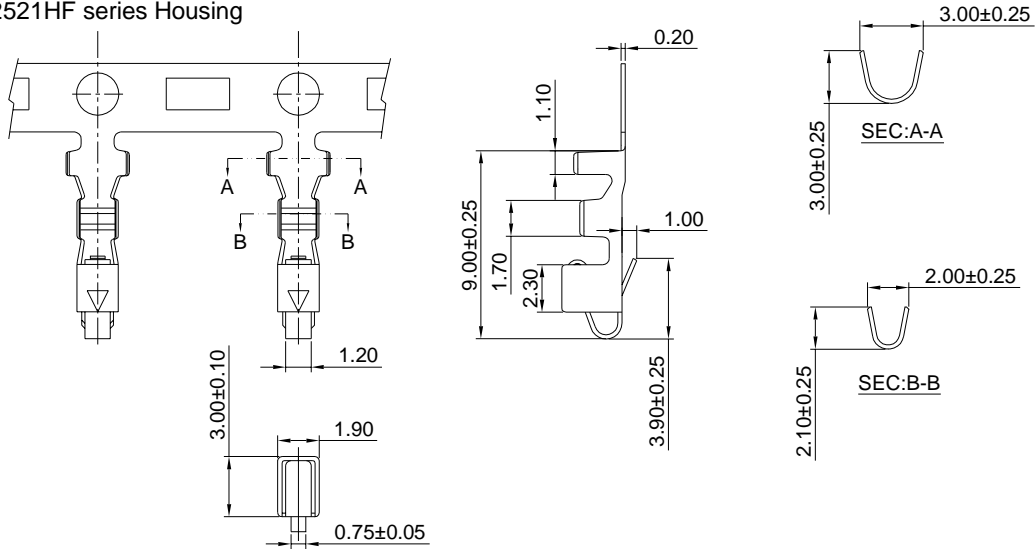

Ordering information & Specifications:

Unit:mm

Part NO.	Wire Range	Insulation O.D.	Material	Finish	Qty/reel
C2521F-TB	AWG#22-#28	1.80mm(max)	Brass	Tin over Nickel	7,000 PCS
C2521F-TP	AWG#22-#28	1.80mm(max)	Phosphor Bronze	Tin over Nickel	7,000 PCS
C2521F-GB	AWG#22-#28	1.80mm(max)	Brass	Gold over Nickel	7,000 PCS
C2521F-GP	AWG#22-#28	1.80mm(max)	Phosphor Bronze	Gold over Nickel	7,000 PCS

Optional Gold plating available but MOQ requested

C2521M-T

2.50mm pitch Crimp Terminal

Reference Informations:

*Used in C2521HM series Housing

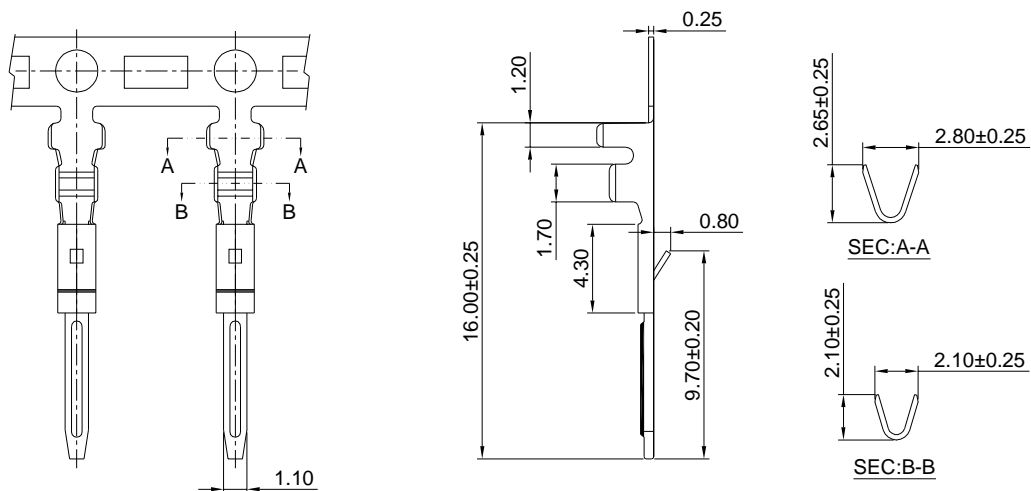

Ordering information & Specifications:

Unit:mm

Part NO.	Wire Range	Insulation O.D.	Material	Finish	Qty/reel
C2521M-TB	AWG#22-#28	1.80mm(max)	Brass	Tin over Nickel	10,000 PCS
C2521M-TP	AWG#22-#28	1.80mm(max)	Phosphor Bronze	Tin over Nickel	10,000 PCS
C2521M-GB	AWG#22-#28	1.80mm(max)	Brass	Gold over Nickel	10,000 PCS
C2521M-GP	AWG#22-#28	1.80mm(max)	Phosphor Bronze	Gold over Nickel	10,000 PCS

Optional Gold plating available but MOQ requested

C2521 SERIES

2.50mm pitch wire to wire connector

C2521HF

2.50mm Pitch Single Row Housing

Reference Informations:

- *Material:Nylon 66,UL94V-0
- *Suitable C2521F series Terminal
- *Mates with C2521HM series Housing
- *Color:Black

Ordering Information:

C2521HF-XP - **
1 2

- 1.Part No.
- 2.Color:
(blank):Black
WH:White

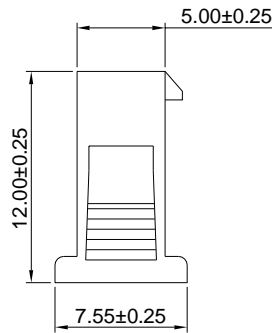
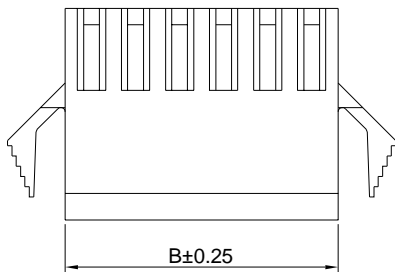
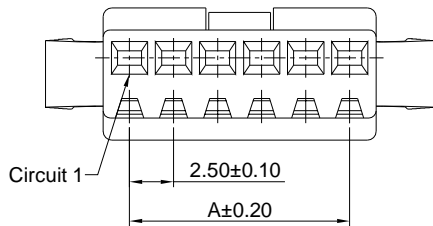
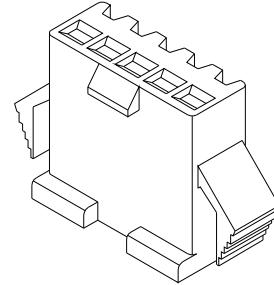

Ordering Information & Dimensions:

PART NO.	Dimensions	
	A	B
C2521HF-2P	2.50	5.50
C2521HF-3P	5.00	8.00
C2521HF-4P	7.50	10.50
C2521HF-5P	10.00	13.00
C2521HF-6P	12.50	15.50
C2521HF-7P	15.00	18.00
C2521HF-8P	17.50	20.50
C2521HF-9P	20.00	23.00
C2521HF-10P	22.50	25.50
C2521HF-11P	25.00	28.00
C2521HF-12P	27.50	30.50

Unit: mm

C2521HM

2.50mm Pitch Single Row Housing

Reference Informations:

- *Material:Nylon 66,UL94V-0
- *Suitable C2521M series Terminal
- *Mates with C2521HF series Housing
- *Color:Black

Ordering Information:

C2521HM-XP - **
1 2

- 1.Part No.
- 2.Color:
(blank):Black
WH:White

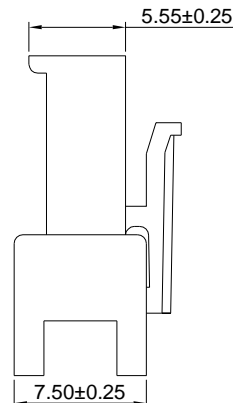
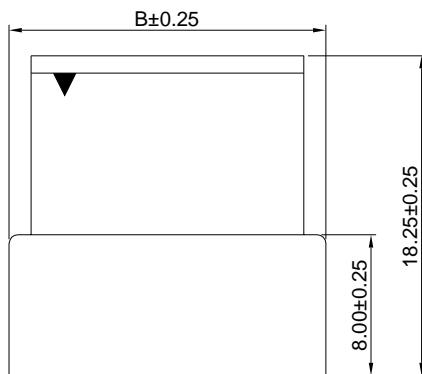
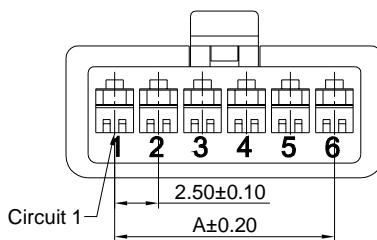
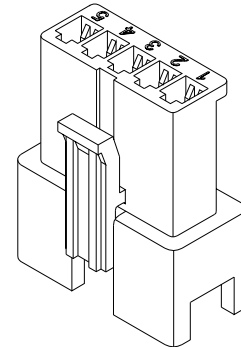

Ordering Information & Dimensions:

PART NO.	Dimensions	
	A	B
C2521HM-2P	2.50	8.00
C2521HM-3P	5.00	10.50
C2521HM-4P	7.50	13.00
C2521HM-5P	10.00	15.50
C2521HM-6P	12.50	18.00
C2521HM-7P	15.00	20.50
C2521HM-8P	17.50	23.00
C2521HM-9P	20.00	25.50
C2521HM-10P	22.50	28.00
C2521HM-11P	25.00	30.50
C2521HM-12P	27.50	33.00

Unit: mm

C2521 SERIES

2.50mm pitch wire to wire connector

C2521HF-2x9P

2.50mm Pitch Dual Row Housing

Reference Informations:

- *Material:Nylon 66,UL94V-0
- *Suitable C2521F series Terminal
- *Mates with C2521HM-2x9P series Housing
- *Color:Black

Ordering Information:

C2521HF-2x9P - **

1	2
---	---

1.Part No.

2.Color:
(blank):Black
WH:White

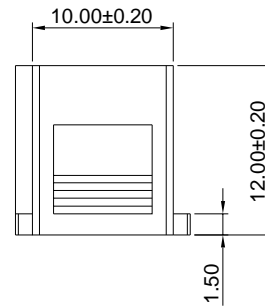
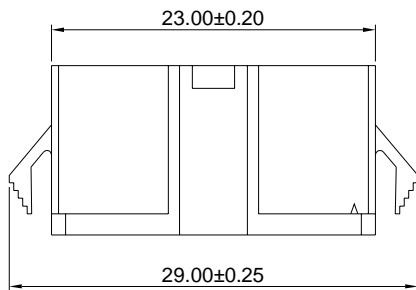
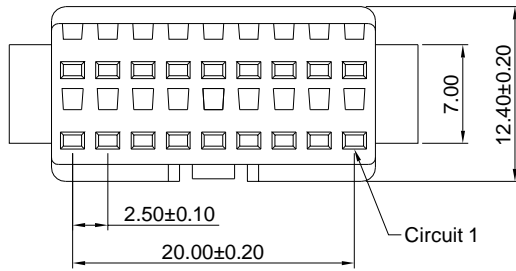
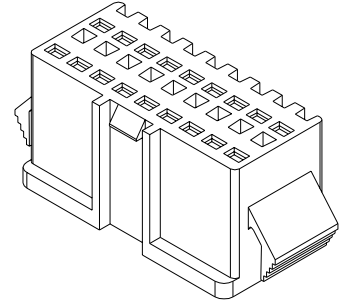

Unit: mm

C2521HM-2x9P

2.50mm Pitch Dual Row Housing

Reference Informations:

- *Material:Nylon 66,UL94V-0
- *Suitable C2521M series Terminal
- *Mates with C2521HF-2x9P series Housing
- *Color:Black

Ordering Information:

C2521HM-2x9P - **

1	2
---	---

1.Part No.

2.Color:
(blank):Black
WH:White

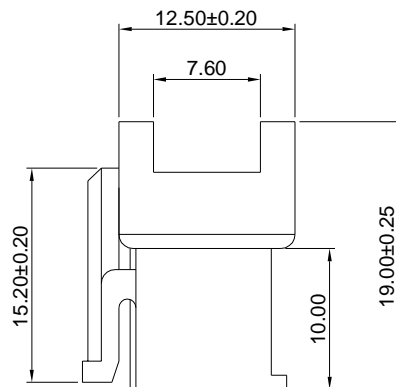
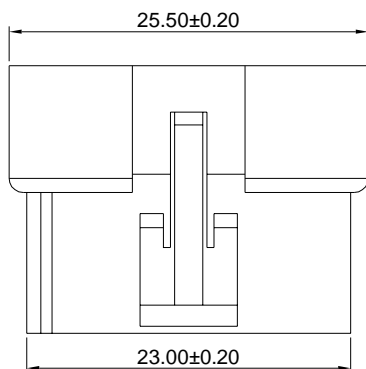
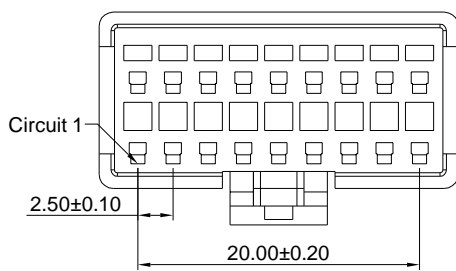
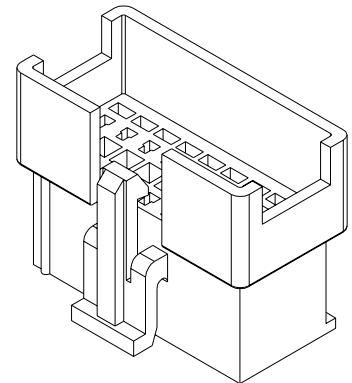

Unit: mm

C2521 SERIES

2.50mm pitch wire to wire connector

C2521S

2.50mm Pitch Retainer

Reference Informations:

*Material:Nylon 66,UL94V-2

*Mates with C2521 series Housing

*Color:White

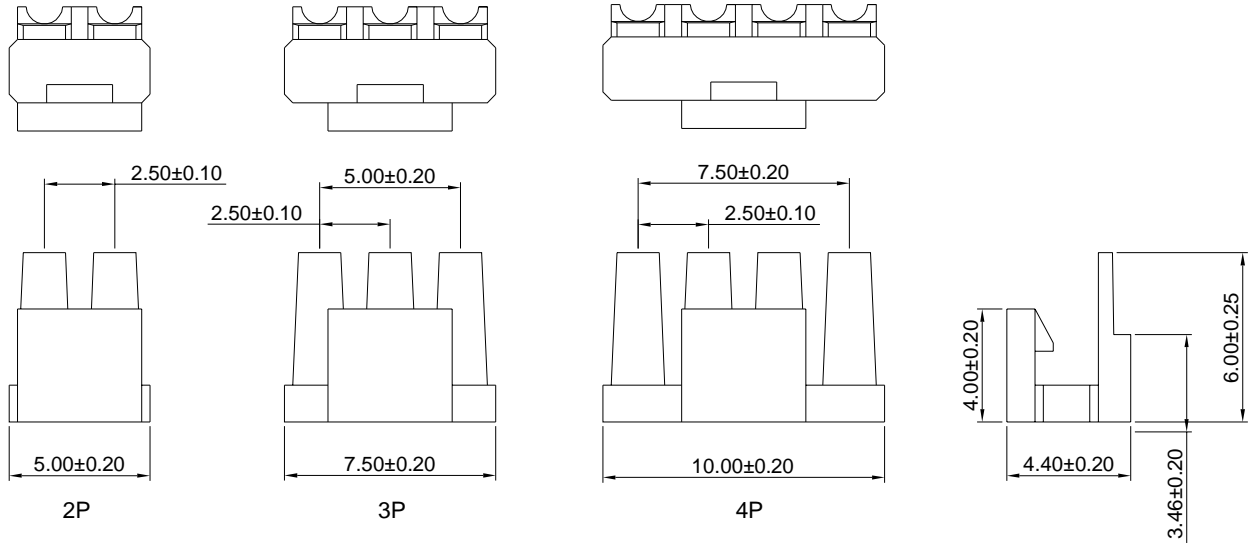

Unit: mm